

Limora Zentrallager
 Industriepark Nord 21
 D- 53567 Buchholz
 Tel: 49 (0) 2683-97990
 E-Mail: Limora@Limora.com
 Internet: www.Limora.com

Filialen:
 • Aachen • Berlin • Bielefeld
 • Düsseldorf • Hamburg
 • Köln • Stuttgart

**Fitting instructions for R.P.L
 Manual choke conversion kit ref: RCK/12
 Suitable for SU Carburettors fitted with an auto-
 matic
 Enrichment device (AED) or automatic starting
 unit (ASU)**

The following chart lists typical applications for the above kit:

model	Carburettor type	Year
Rover 3.5 V8 P5	HS6 AED	1968-69
Rover 3500 V P6	HS6 AED	1968-70
Ambassador HLS	HIF44 ASU	1982-84
Ambassador V.P.	HIF44 ASU	1982-84
Daimler Limousine	HS8 AED	1973-76
Daimler Sovereign	HS8 AED	1971-75
Daimler Sovereign	HIF7 AED	1975-86
Jaguar 2.8 XJ6	HS8 AED	1971-73
Jaguar 3.4 XJ6	HS8 AED	1975-76
Jaguar 3.4 XJ6	HIF7 AED	1975-86
Jaguar 4.2 XJ6	HS8 AED	1971-75
Jaguar 4.2 XJ6	HIF7 AED	1975-86

1.0 General

1.1 AED: Fitted to Jaguar/Daimler and Rover.

The device is mounted at high level between the carburettors and incorporates an integral float chamber. A single diaphragm operates the fuel needle.

1.2 ASU: Fitted to Austin Ambassador HLS/Vanden Plas 2.0 litre. The unit is mounted on the extended off-side carburettor bottom cover, and is fed by fuel from the carburettor float chamber. The fuel needle is operated by twin diaphragms.

1.3 In the normal automatic mode, the device/ unit provides auxiliary enrichment and never completely shuts off. During its operating life a gradual degradation of bimetal performance occurs permitting an every increasing output of fuel enriched air.

At each service the above worsening condition is usually countered by a progressive leaning of carburettor settings and an adjustment to fast die stops.

The change to a manually operated device provides positive shut-off for both fuel and air, necessitating readjustment of carburettor settings. In some cases, complete removal of the carburettors may be necessary if general refurbishment is considered essential. The following sequence of operations consters only the fitting of a manual device with least disturbance to the system.

1.4 Tuning Carburettors

It will be necessary to re-adjust the mixture settings on both carburettors prior to fitting manual conversion kit This can be achieved by starting the engine and running to normal temperature, then disconnecting AED/ASU mixture outlet pipe to induction manifold and blanking off manifold. The enrichment device now being out of circuit, the carburettors can be re-adjusted to the correct mixture and balanced.

2.0 AED – Jaguar/Daimler XJ6 and Rover

2.1 Removal of AED unit

- Disconnect the battery earth lead.
- Disconnect the enrichment device mixture pipe.
- Disconnect the hot air supply pipe from the exhaust manifold.
- Disconnect the fuel supply pipe from the float chamber.
- Disconnect the vent pipe.
- Remove screws securing AED to mounting bracket.

2.2 With AED on the bench: refer to Fig. 1.

- Remove black heat insulation cover.
- Remove two screws and the black top cover. Retain the screws for later use.
- Remove main bi-metal which operates the air valve and discard.
- Remove gasket and discard.
- Ease off small collet securing valve spring to air valve spindle, discard spring but retain collet.
- Remove flat fork ended tensioner (if fitted) and discard.
- Lightly clean/oil the air valve spindle, checking for freedom of movement. A carbon deposit builds up around the air valve spindle limiting full valve axial movement. Gentle manipulation of the air valve spindle will dislodge the deposit, giving a full travel of approximately 0.180 ins (4.5mm).
- Refer to Fig. 3. Place the new valve spring, supplied with the kit, over the air valve spindle and secure with collet retained in (e). Note that on early ASU/AED air valves, the spindle is much shorter in length necessitating fitment of the extension piece supplied in the kit, as detailed in Inset X.
- Invert the AED, remove the four screws and washers and detach the bottom cover. Replace the old diaphragm with

the new item supplied in the kit ensuring that the compression spring and ferrule interconnector are refitted in the correct positions. Secure the cottom cover with four screws and washers.

2.3 Trial fit of AED and manual adaptor (Refer to ASU illustration in fig. 4)

- (a) Remove the manual adaptor camshaft cradle by unfastening its two cradle screws.
- (b) Adjust length of screws removed in 2.2 b) to suit counterbores in adaptor body. Check heads of screws for clearance in counterbores, lightly file outside diameter of screw head if necessary.
- (c) Fasten adaptor body to AED unit, carefully centralise the body, ensuring that the air valve tappet operates the air valve without restriction.
- (d) Refit the adaptor camshaft cradle with two screws and shakeproof washers.
- (e) With the camshaft lever arm in its springloaded back stop position (OFF) each cam should have its respective tappet fully depressed, cutting off fuel/air. With the two cam grub screws slackened and looking at the non-drive end of the camshaft, rotate each cam in turn anti-clockwise until first the fuel needle tappet and then the air valve tappet are fully down, lock the grub screws. Move the lever arm against spring tension to the full-on position, both tappets should rise with a gap appearing under the fuel needle cam.

NOTE: The standard setting of fuel needle tappet clearances are adequate for most applications.

- (f) For optimum performance, the fuel needle cam should be approaching bottom dead centre in the „OFF“ position, refer to Inset Y. Current experience has shown that a gap of .030 ins shown between head of tappet and top of bush results in the best response. This can be achieved by shortening the tappet. Remove the camshaft cradle, extract the tappet from the bush and lightly grind its small diameter end. Refit the cam and cradle, check and readjust to give required results.
- (g) Remove complete manual adaptor assembly prior to refitting AED onto vehicle.

2.4 Refitment of AED and manual adaptor

- (a) Fit the AED back onto the mounting bracket between the carburettors.
- (b) Reconnect the mixture pipe to the inlet manifold.
- (c) Reconnect the air supply pipe – this incorporates a filter, make sure it is not blocked.

This check is most important as loss of fast idle results from even partial restriction.

- (d) Reconnect the fuel supply and vent pipe.
- (e) Reconnect the battery earth lead.
- (f) Start the engine, with the new spring providing full lift on the air valve, engine revs should be in excess of 1.500 rpm. Manifold depression should be holding the fuel needle fully down on its seat, if not, check the diaphragm is correctly orientated.

Referring to Fig. 3. depress the air valve on to its seat and slowly release, observing engine reaction. If the engine momentarily stalls, turn the square headed mixture adjusting screw down no more than 15°.

On collapse of manifold depression, the fuel needle should momentarily rise, enrichening the mixture. Clockwise rotation of the mixture adjusting screw produces a leaner mixture.

Tuning skills play an important part at this stage in assessing the direction and amount of movement required. The screw adjustment is extremely sensitive, very small adjustments resulting in dramatic changes in enrichment.

Time spent adjusting enrichment at this stage, to give good engine response with air valve movement, results in a very smooth manual choke operation.

- (g) When a satisfactory response is achieved, replace the manual adaptor over AED and secure with the two screws and shakeproof washers; Check freedom of movement of air valve tappet prior to tightening screws.
- (h) Check that the cams operate correctly in shutting off the fue/air when the manual control is operated, re-adjust if necessary.

3.0 ASU – Ambassador

3.1 Removal of ASU

- (a) Disconnect the battery earth lead.
 - (b) Remove the air cleaner.
 - (c) Disconnect the enrichment device mixture pipe.
 - (d) Disconnect the hot air supply pipe from the exhaust manifold.
- NOTE:** A small mirror is useful at this stage to locate blind screws, position a cloth to catch any falling parts.
- (e) Loosen the screw securing the ASU support bracket from below, leaving the bracket in position.
 - (f) Remove four small screws under ASU sandwiching unit from below.
 - (g) Lift out lower cap and diaphragm taking care to retrieve small connecting plunger and ferrule.
 - (h) Lift off ASU from sandwich plate/carburettor bottom cover.
 - (i) Remove upper diaphragm with two ferrules from the top of compression spring, remove the spring.

3.2 With ASU on the bench: refer to Fig. 2

- (a) Remove black heat insulation cover.
- (b) Remove two screws and the black top cover. Retain the screws for later use.
- (c) Remove main bi-metal which operates the air valve and discard.
- (d) Remove gasket and discard.
- (e) Ease off small collet securing valve spring to air valve spindle, discard spring but retain collet.
- (f) Remove flat fork ended tensioner (if fitted) and discard.
- (g) Lightly clean/oil air valve spindle checking for freedom of movement A carbon deposit builds up around the air valve spindle limiting full valve axial movement. Gentle manipulation of the air valve spindle will dislodge the deposit giving a full travel of approximately 0.180 ins (4.5mm).
- (h) Refer to Fig 3: place the new valve spring, supplied with the kit, over air valve spindle and secure with collet retained in (e).

3.3 Trial fir of ASU and manual adaptor

- (a) See 2.3 and follow instructions a) to g), referring to Fig. 4. Owing to the partially dismantled state of the ASU, the fuel needle will not be supported by the spnng loaded diaphragm and hence not rise/fall under influence of cam. In all other respects, the above instructions apply, or both AED and ASU.

3.4 Refitment of ASU and manual adaptor

- (a) Refer to Fig. 2. Insert one sandwich fixing screw with washer through lower ASU cap. Fit one new diaphragm on the cap, large central copper head uppermost, and with the brass ferrule on the position shown in Fig. 1. Re-locate the assembly under the sandwich plate.
- (b) Replace connecting plunger from 3.1 (g) and the compression spring, ensuring the spring is correctly located.
- (c) Place second new diaphragm over compression spring with large central cooper head uppermost, one brass ferrule in a hole next to the carburettor body, the other in the hole nearest the locating bracket

NOTE: It is important that both diaphragms are correctly

orientated to their mating parts, there are three small passages which must be aligned, these have brass ferrule inter-connectors that must be refitted as detailed above.

- (d) Place ASU onto sandwich plate over diaphragm and spring, fasten the fixing screw and tighten the support bracket screw.
- (e) Refit the other three screws and washers to the lower cap.
- (f) Reconnect the mixture pipe to the inlet manifold.
- (g) Reconnect the air supply pipe - this incorporates a filter, make sure it is not blocked.

NOTE: If the cost of replacing filter is considered prohibitive, normal air flow may be restored by the introduction of a blunt instrument across filter face!

- (h) Reconnect the battery earth lead.
- (i) Start the engine, with the new spring providing full lift on the air valve, engine revs should be in excess of 1,500 rpm. Manifold depression should be holding the fuel needle fully down on its seat, if not, check the two diaphragms are correctly orientated.
- (j) Depress the air valve on to its seat and slowly release observing engine reaction. If the engine momentarily stalls, turn the square headed mixture adjusting screw down no more than 15°.

On collapse of manifold depression, the fuel needle should momentarily raise, enriching the mixture. Clockwise rotation of the mixture adjusting screw produces a leaner mixture.

As with the AED tuning skills play an important part at this stage in assessing whether the mixture is too rich or weak. The screw adjustment is extremely sensitive, very small adjustments resulting in dramatic changes in enrichment

Time spent adjusting enrichment at this stage, to give good engine response with air valve movement, results in a very smooth manual choke operation.

- (k) When a satisfactory response is achieved, replace the manual adaptor over ASU and secure with the two screws and shakeproof washers. Check freedom of movement on air valve tappet prior to tightening screws.
- (l) Check that the cams operate correctly in shutting off the fuel/air, re-adjust if necessary.

4.0 Installation of choke cable

- 4.1 Locate choke bracket under the dash in a suitable position. Using the bracket as a template, mark out position of screw holes, then drill 3.5mm/0.1378" and fix bracket with the self tapping screws.
- 4.2 Thread choke cable through interior mounting bracket and loosely clamp with lock washer and nut.
- 4.3 Run cable from inside vehicle, utilising an existing convenient grommet.
- 4.4 Clamp the outer cable cover to manual choke unit cable clamp with minimum cover protrusion through clip.

NOTE: On certain models, it will be beneficial to shorten the cable length to provide a „kink free“ run. Use a sharp pair of wire cutters.

- 4.5 With the choke knob pushed „fully in“ and knob bayonet firmly clamped to interior bracket, clamp inner cable to the nipple on the operating lever.
- 4.6 Check the mechanism for freedom of movement, full travel of the knob should be approximately 1.2"/30.5mm.

5.0 Fascia mounted installation

- 5.1 Locate a suitable place on fascia, making sure sufficient clearance exists behind the selected position.
- 5.2 Drill a hole in the fascia to accept knob bayonet diameter (0.5"/12.7mm).
- 5.3 Feed cable through the fascia and fit lock nut/washer.

See instructions 4.3 to 4.6.

6.0 Installation of optional light kit

6.1 Bracket mounted light

- (a) Fit small ring terminal to one end of the black wire and put this terminal under one of the heads of the self tapping screws.
- (b) Snap the Brycrest choke switch onto body of choke knob. This only fits one way, the three small holes in choke body will precisely accommodate the two black pegs and white plunger.
- (c) Trim the black wire, fit a female spade connector and push onto either Brycrest switch terminal.
- (d) Push the warning light into the bracket
- (e) Cut a suitable length of red cable and fit a female terminal and insulator to each end.
- (f) Attach one end of red cable to warning light and the other to remaining terminal of choke switch.
- (g) Take the remaining red cable and fit a female terminal plus insulator to one end, and attach to remaining terminal on warning light.
- (h) Route the other end of the red cable and connect the blue Scotchlok connector, to a fused ignition controlled power source (eg: Heater, Ignition, Radio, etc.).

6.2 Fascia mounted light

- (a) The only difference in using the fascia for a mounting point is that, provided the choke body passes through the metal work of the fascia, the large ring terminal for the earth may be used.
- (b) Fix the large ring terminal to one end of the black wire and a female spade connector to the other end.
- (c) Drill two holes in the fascia for the cable and warning light (0.5"/12.7mm diameter maximum).
- (d) Feed the cable through the fascia and place the large ring terminal onto the cable body before the washer and locknut.
- (e) If the fascia is non-metallic, it will be necessary to use the small ring terminal with a suitable earthing point.

7.0 Functional checks

- (a) Turn on ignition and check for correct operation of choke warning light.
- (b) Refit air cleaner, if removed, and check that all vacuum hoses are re-connected.
- (c) Using sufficient choke compatible with ambient conditions. start the engine.
- (d) Set the idle speed to the manufacturers recommendation when the engine is warm.
- (e) Even with engine cold, as soon as traffic conditions allow continuous use of top gear, choke should be immediately reduced to the minimum satisfactory position. For warm starts it should not be necessary to use the choke.

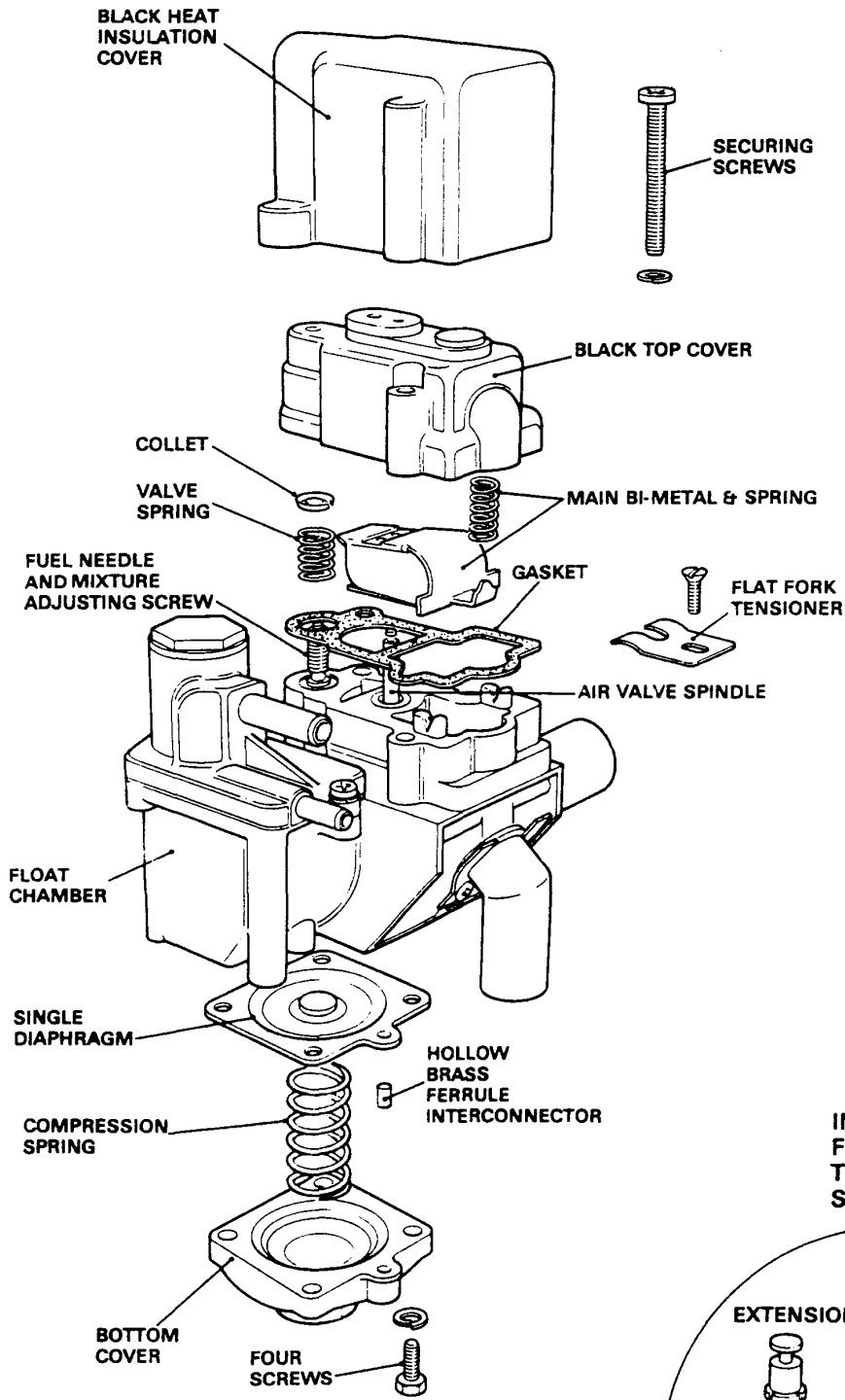
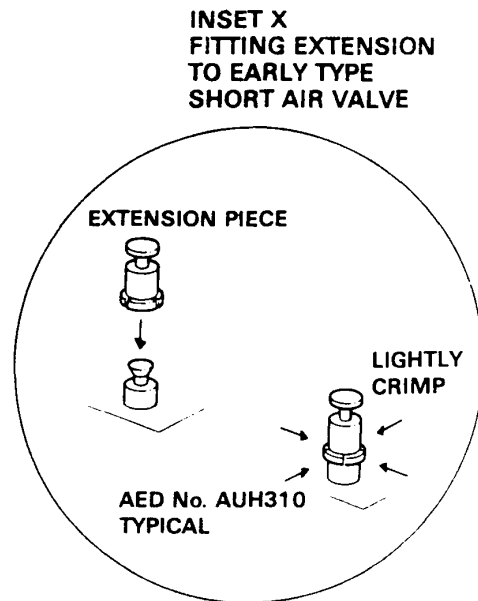

FIG 1 AED - JAGUAR/DAIMLER AND ROVER



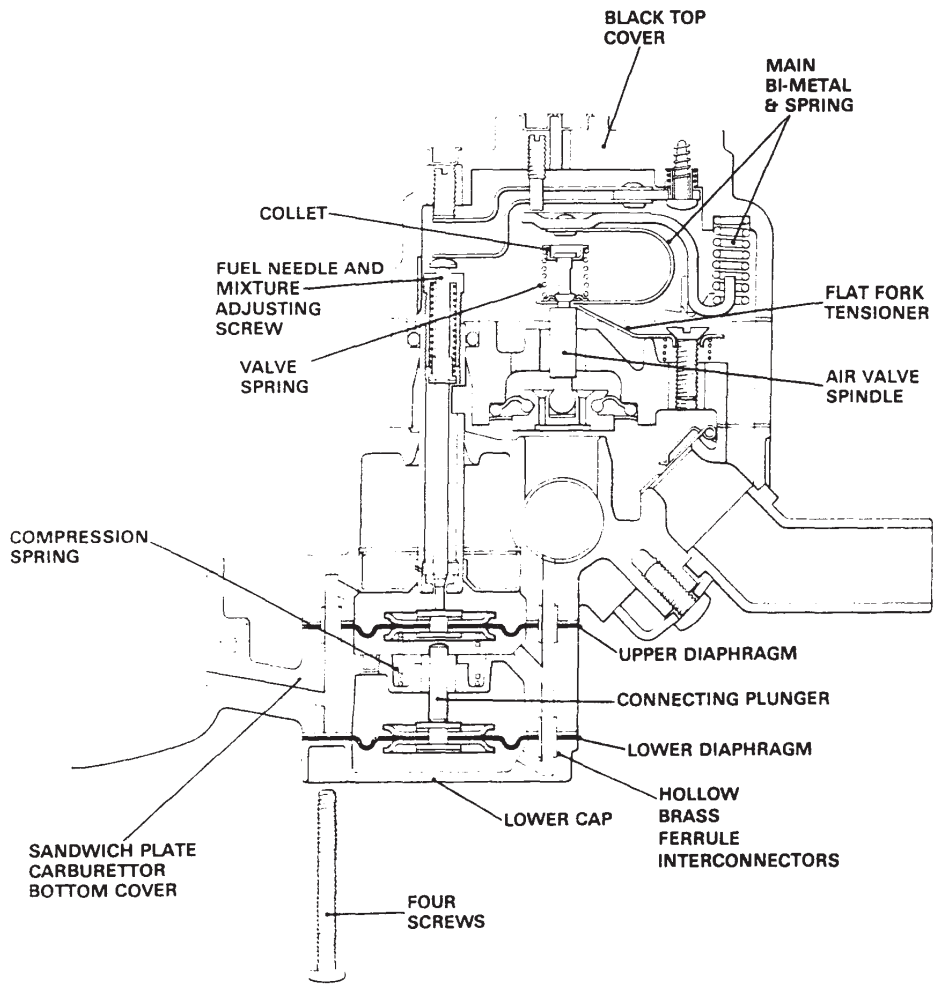

FIG 2 ASU - AMBASSADOR

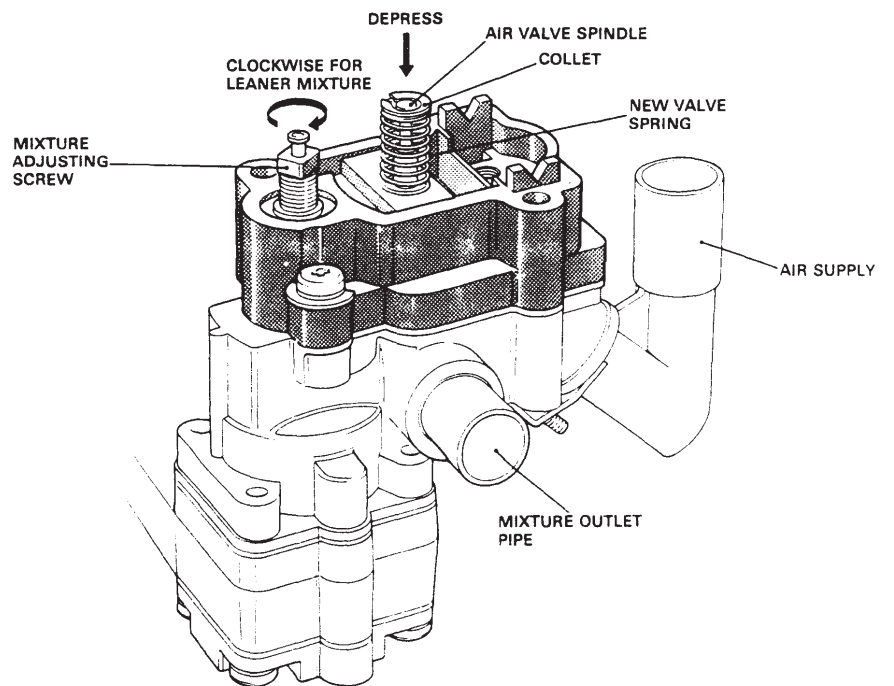

FIG 3 MIXTURE ADJUSTMENT

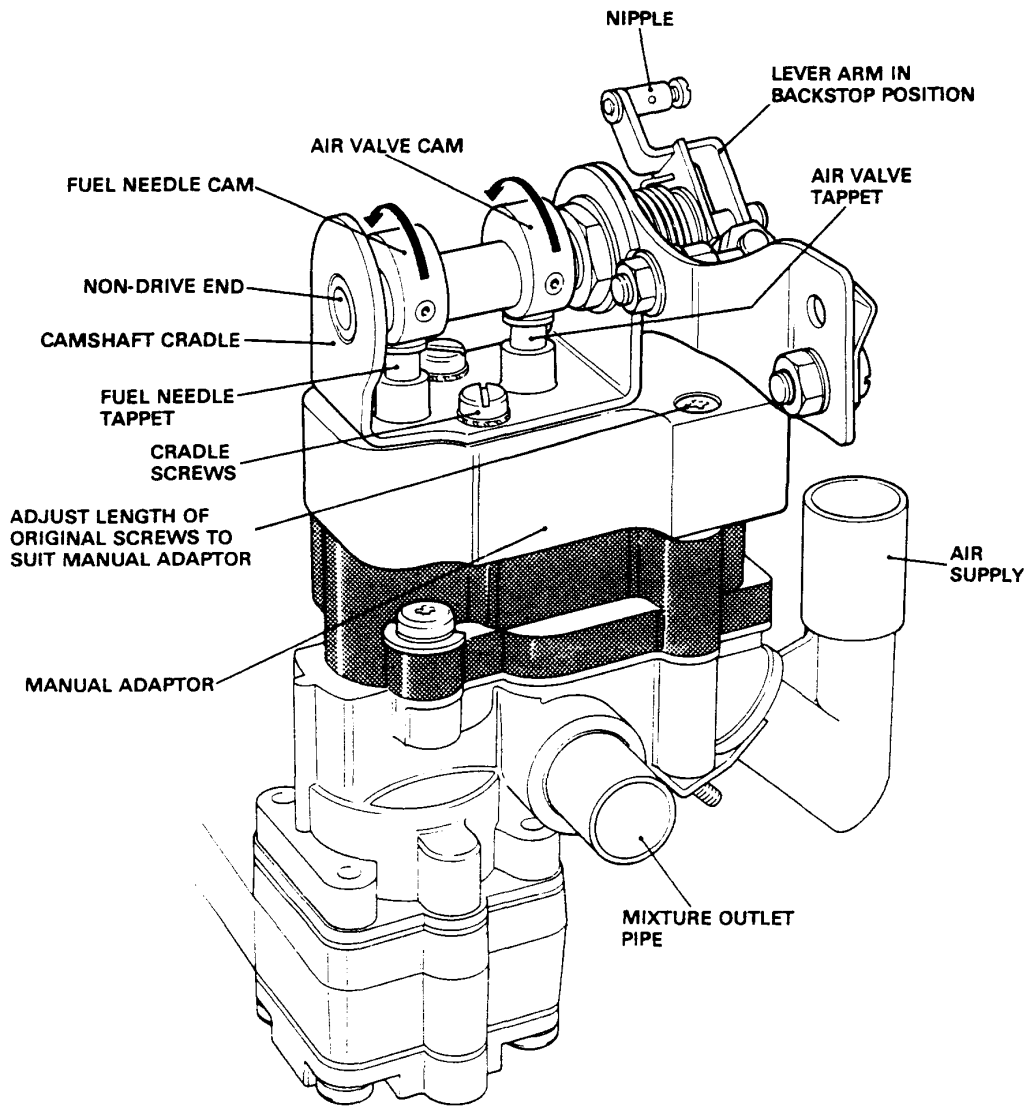

FIG 4 FITTING AND SETTING MANUAL ADPATOR

INSET Y OPTIMUM SETTING OF FUEL NEEDLE TAPPET

