

**Limora Zentrallager**

Industriepark Nord 21  
 D - 53567 Buchholz  
 Tel: +49 (0) 26 83 - 97 99 0  
 E-Mail: Limora@Limora.com  
 Internet: www.Limora.com

**Filialen:**

- Aachen • Berlin • Bielefeld
- Düsseldorf • Hamburg
- Köln • Stuttgart

**MG TD/TF Sierra Gearbox Conversion Fitting Instructions**

This gearbox conversion is designed for adapting the Ford Type 9 gearbox, 5 speed, as fitted to the Ford Sierra 1983-91, to the MG TD!TF. This gearbox is referred to as ,N' type in the Haynes owner's workshop manual for the Ford Sierra.

**Safety**

There is considerable work required underneath the vehicle when fitting this conversion. Consequently the use of a vehicle inspection pit or vehicle lift is recommended. If these are not available the car will need raising front and back to give sufficient space to work safely and comfortably under the engine, gearbox/ propshaft areas. To accomplish this, support the car front and rear with properly sized and located axle stands. Do not use vehicle or trolley jacks for permanent support, only for raising and lowering the car.

**The conversion kit comprises the following parts:**

1. Cast Aluminium Bell Housing 5/8" or 3/4" cross shaft
2. Gasket, bellhousing to gearbox
3. Spigot bush
4. Rear rubber gearbox mounting
5. Modified front rubber engine mounting
6. New gearbox support crossmember
7. Two gearbox crossmember side supports/ lockplates
8. Engine mounting packing plate
9. Exhaust support bracket
10. Engine torque reaction bracket/ bolt
11. Two floor rail support brackets
12. Gear lever assembly - chrome
13. Clutch plate, driven, for 7 1/4" or 8" pressure plate
14. Speedometer cable/ circlip
15. Brake pipe (RHD only)
16. Fan spacer, reduced, plus 4 bolts. TF only
17. Modified front wing tie bar. TF only
18. Propshaft assembly
19. Gearbox cover with safety guard in moulded ABS
20. All bolts and fasteners
21. Detailed fitting instructions
22. Loctite

**General Philosophy**

The cast aluminium bell housing replaces the Ford cast iron bell housing from the Sierra application. The TD/TF clutch operating mechanism is re-used in the new bell housing and operates exactly as before. The only changed component is the driven plate supplied with kit.

A new spigot bush to accept the 15mm first motion shaft of the Ford gearbox replaces the existing bush. The TD/TF clutch cover is re-used with the driven plate supplied, as is the original type carbon thrust bearing.

A new gearbox mounting/ crossmember and support brackets are clamped to the original gearbox tubular crossmember and supports the gearbox using the Ford gearbox mounting point. To enable the gearbox to be fitted into the gap between the vehicle front crossmember and the gearbox crossmember without removing the crossmember, two steps have been taken:

1. The bell housing is 3/8" (10mm) shorter than the original
2. The engine is moved 3/8" (10mm) forward by using a new engine mount with offset studs.

On LHD vehicles the new engine mount is reduced in thickness in order to lower the engine. This is necessary to maintain the original clearance between the underside of the steering column and the oil pump which projects out from the left hand side of the engine. The sequential effect of this engine forward movement is summarised below.

1	Coolant hoses	Will accept movement
2	Fuel system	Will accept movement
3	Fan/radiator clearance	TD adequate clearance TF reduced fan spacer, and modified wing tie bar supplied
4	Engine stabiliser bar	Offset bracket fitted to water pump
5	Clutch	Will adjust new location
6	Exhaust	Will accept forward movement however, Tailshaft of gearbox 3/8" (10mm) higher than original, consequently exhaust system is 3/8" (10mm) closer to underside of vehicle. System will require some re-routing to maintain original chassis clearances
7	Choke cable	Will accept movement
8	Front engine plate	Will contact engine stabiliser tower – bolt relocated and small piece of metal removed – see diagrams
9	Starting handle	RHD – not affected LHD – due to engine being slightly lower than normal, starting handle hole in front chassis crossmember may require opening out to allow handle to line up with starting dog.

A new balanced propeller shaft complete with Sierra gearbox splined nose piece is supplied which replaces the original shaft.

**Limora Zentrallager**

Industriepark Nord 21  
 D - 53567 Buchholz  
 Tel: +49 (0) 26 83 - 97 99 0  
 E-Mail: Limora@Limora.com  
 Internet: www.Limora.com

**Filialen:**

- Aachen • Berlin • Bielefeld
- Düsseldorf • Hamburg
- Köln • Stuttgart

A modified extended gear lever is supplied which puts a new MG replica chrome gear lever into the exact position as original.

A new moulded ABS gearbox cover is supplied to cover the longer gearbox. A 16 SWG additional propeller shaft guard is incorporated into the rear of the cover, this must be bolted through the floor boards and support rails.

A new speedometer cable is supplied which adapts the Sierra gearbox speedometer drive to the MG instrument, which must be recalibrated to suit the new gearbox speedometer drive ratios.

**Note: Chronometrie Speedometer Early TD.**

This type of instrument is difficult and expensive to recalibrate. Hi-Gear Engineering has commissioned Speedograph Richfield to manufacture, to order, a small step up gearbox which will fit directly into the speedo cable entry point on the Ford Type 9 gearbox.

This step up gearbox will then drive the original cable to the speedometer.

The vehicle owner sends his speedo together with calibration data obtained from the vehicle to Speedograph Richfield who will check the instrument and supply the step up gearbox with correct ratio for accurate speed indication.

The step up gearbox Ref. is RGB 1030  
 See attached information sheet on Speedograph Richfield.

**Sierra Gearbox Preparation**

1. Remove the Sierra bell housing and clutch release mechanism from the gearbox and discard.
2. At the front of the gearbox remove the four bolts and withdraw the clutch release bearing guide sleeve, note the orientation of the guide sleeve base. The small protuberance on the base points towards the bottom of the gearbox.
3. Carefully, using a hacksaw, saw off the parallel sleeve from the base leaving approximately 1 cm of sleeve on the base. De-burr and remove filings, clean oil seal thoroughly. The sleeve is not required.
4. Lubricate oil seal and shaft and replace base in correct position on gearbox. Replace cork gasket if damaged, again noting orientation with the gasket cut out at the bottom. Replace and tighten bolts, 7-8 lb ft, 9-11 Nm.

5. The rear gearbox extension casing is fixed to the main case with 6 x 10mm bolts.

Remove the lowest bolt on RHS of gearbox and replace with 90mm long bolt and washer. Tighten to 30 lb ft (40Nm). This new bolt goes through the extension flange, sandwich plate and main case flange and protrudes through under the main case. The exhaust bracket is secured by the end of this 10mm bolt with a washer and self lock nut. It is prevented from moving by a dowel which locates into the Sierra dowel hole adjacent to it. The original exhaust pipe clip is then bolted to the bracket using a 10mm bolt and nut. - see diagram.

6. Remove metal from gearbox rear casing as shown in the diagram. This is to give maximum clearance between gearbox and original chassis crossmember.

**Vehicle Preparation**

1. Remove  
 Steering wheel (LHD, steering column)  
 Seats, carpets  
 Gearbox cover  
 Floorboards  
 Propshaft cover  
 Floor support rails  
 Gearbox and clutch operating rod/cable
2. Remove  
 Bonnet  
 Radiator  
 Front wing Tie bar (TF only)  
 Fan blades, spacer  
 Water pump pulley  
 Engine stabiliser bar (complete)
3. Loosen exhaust support clamps  
 It is possible to change the gearbox and to do all work for the conversion without removing the engine but good access is required from the underneath to change the engine mounting and access from the front for work on front engine plate and engine stabiliser bar.  
 In this case remove gearbox from inside car, having suitably supported engine. Alternatively, the engine and gearbox can be removed as a unit and replaced as a unit.

**Chassis preparation**

See diagram

**Limora Zentrallager**

Industriepark Nord 21  
D - 53567 Buchholz  
Tel: +49 (0) 26 83 - 97 99 0  
E-Mail: [Limora@Limora.com](mailto:Limora@Limora.com)  
Internet: [www.Limora.com](http://www.Limora.com)

**Filialen:**

- Aachen • Berlin • Bielefeld
- Düsseldorf • Hamburg
- Köln • Stuttgart

**Assembling the new bell housing**

1. Remove the clutch operating shaft and fork from original bell housing.
2. Replace them in the new conversion bell housing, noting the correct orientation of all parts. If any parts are worn it is a good policy to replace them at this time.
3. Clean the four 12mm bell housing attachment bolts in solvent to remove oil/grease. Similarly clean the four 12mm threaded attachment holes on the Sierra gearbox. Assemble the bell housing and gearbox together with the supplied gasket between. Apply LOCTITE (supplied) to the threads of the attachment bolts and gearbox attachment hole threads.

Using the spring washers with the 12mm bolts torque them to 55 lb ft (75Nm). Replace carbon thrust bearing.

4. Mark the clutch cover and flywheel so that they can be reassembled in the same position to preserve engine balance.
5. Remove clutch cover and driven plate.
6. Remove spigot bush from end of crankshaft using a hacksaw blade to make one clean cut along the bearing. Clean up the hole.
7. Insert new spigot bush into the vacated hole and drive squarely and evenly in to the same depth as original.
8. Apply a little grease to the centre hole of spigot bush for initial lubrication. Do not use copper grease.
9. Assemble the clutch cover and new driven plate in the normal way (use a Sierra clutch alignment tool if available).
10. If the engine/gearbox are out of the car it is a good idea at this point to assemble the gearbox and bell housing to the engine to see that all is well. Bolt gearbox/bell housing to the engine using the 8mm x 35mm bolts supplied.
11. Fit gear lever assembly with the bolts supplied.
12. Remove sparking plugs, rotate engine and verify that all gears can be obtained and everything rotates freely and easily.

The above test can be done if the engine remains in the car, after gearbox is attached.

13. Refit gearbox to engine from inside car OR
14. Refit engine/ gearbox as a unit.

For 13 and 14 above for LHD cars the steering column should be removed.

15. With gearbox/ engine in car and with new engine mounting in position the engine/ gearbox will be 10mm forward of original position.
16. Allow gearbox to rest on chassis crossmember. Fit new gearbox rubber mounting to the gearbox mounting point with single 12mm bolt and spring washer. Torque to 37 lb ft (50Nm) and use Loctite.
17. Carefully jack up gearbox until new mounting touches original brackets. Fit new preassembled gearbox crossmember and side clamps as per diagram. Align top of clamps with top of chassis members - See diagram  
Tighten up bolts evenly and torque to 35 lb ft (46Nm). Bend over lock tabs.  
Lower gearbox down until weight is taken by new crossmember. Fit bolts with collars (lateral safety stops), which attach rubber mounting to new crossmember. Ensure gearbox is exactly central to chassis and tighten up the securing bolts to 20 lb ft (27 Nm).  
Check for adequate gearbox to chassis clearance and on LHD cars check adequate (original) clearance between steering column and oil pump. This is important.  
On RHD models refit brake pipe - see diagram

18. Fit new propshaft. Lubricate spline and outer surface of nose piece. Bolt up flange as before - use new locknuts.

**Note:** Before bolting up flange: the threaded part of the pinion, which passes through locknut and is visible inside axle drive flange sometimes is long enough to prevent these new type propshaft flanges from locating correctly on axle drive flange. It may be necessary to grind off one or two threads to allow the flanges to register correctly.

19. Fit new speedo cable. This takes the same route as original. The gearbox termination is secured with a circlip. You will need a fine pair of circlip pliers. This is not easy to fit.
20. Fit new floor rail supports onto outer holes of original gearbox mounting brackets with 3/8" UNP bolts/locknuts supplied. Note RH and LH.

**Limora Zentrallager**

Industriepark Nord 21  
D - 53567 Buchholz  
Tel: +49 (0) 26 83 - 97 99 0  
E-Mail: [Limora@Limora.com](mailto:Limora@Limora.com)  
Internet: [www.Limora.com](http://www.Limora.com)

**Filialen:**

- Aachen • Berlin • Bielefeld
- Düsseldorf • Hamburg
- Köln • Stuttgart

21. Fit floor rails having modified them as per diagram (Chassis preparation).
22. Refit propshaft tunnel having shortened it as per diagram. (Chassis preparation).
23. Refit floorboards. They will need considerable trimming in order to fit around the new gearbox. Allow 10mm all round clearance.  
You will need to cut a piece out of the floorboard on LHS, front, under the bulge in the gearbox cover in order to give access from underneath to the filler/level plug of the gearbox, cut out 3" x 2" (75 x 50mm) around filler plug. This allows hexagon key or square key to remove/tighten plug.
24. Fit new gearbox cover. Centralise cover and ensure fully forward. Make new holes in horizontal flanges and bolt up with 6mm bolts/nuts/washers. The rear of the gearbox cover incorporates an additional guard, this must be bolted through the floorboard and floor rail to be secure and effective.
25. Refit gear lever using 3 x M8 screws /washers supplied. Grease mechanism liberally inside gear lever aperture.

**Front of car**

26. Fit new bracket to offset engine stabiliser bar.
27. Fit stabiliser bar; Refit water pulley/fan

On LHD cars check that the starting handle can easily reach the starter dog and turn the engine.

As the engine is slightly lower the starter handle hole in the front chassis crossmember may need to be elongated downwards to allow the handle to operate normally.

28. TF Models: Fit new wing tie bar, incline slightly forward to give clearance to thermostat housing.
29. Fit new fan spacer, with fan blades and new bolts/spring washers.
30. Refit radiator. Check fan/radiator clearance.

Check that fan belt can be fitted easily. Refit all hoses.

31. Check all vehicle services and operation.

RHD models - bleed brakes

32. Fill gearbox with Ford Synthetic oil fill to level hole on LHS of gearbox. Access is only from below.
33. Check car for roadworthiness.
34. Check engine and clutch operation.
35. Road Test.
36. After 100 miles (160 km) recheck tightness of all newly installed bolts/nuts. RHD, check new brake pipe for leaks.

**Limora Zentrallager**  
 Industriepark Nord 21  
 D - 53567 Buchholz  
 Tel: +49 (0) 26 83 - 97 99 0  
 E-Mail: [Limora@Limora.com](mailto:Limora@Limora.com)  
 Internet: [www.Limora.com](http://www.Limora.com)

**Filialen:**  
 • Aachen • Berlin • Bielefeld  
 • Düsseldorf • Hamburg  
 • Köln • Stuttgart

## LEFT HAND DRIVE CARS

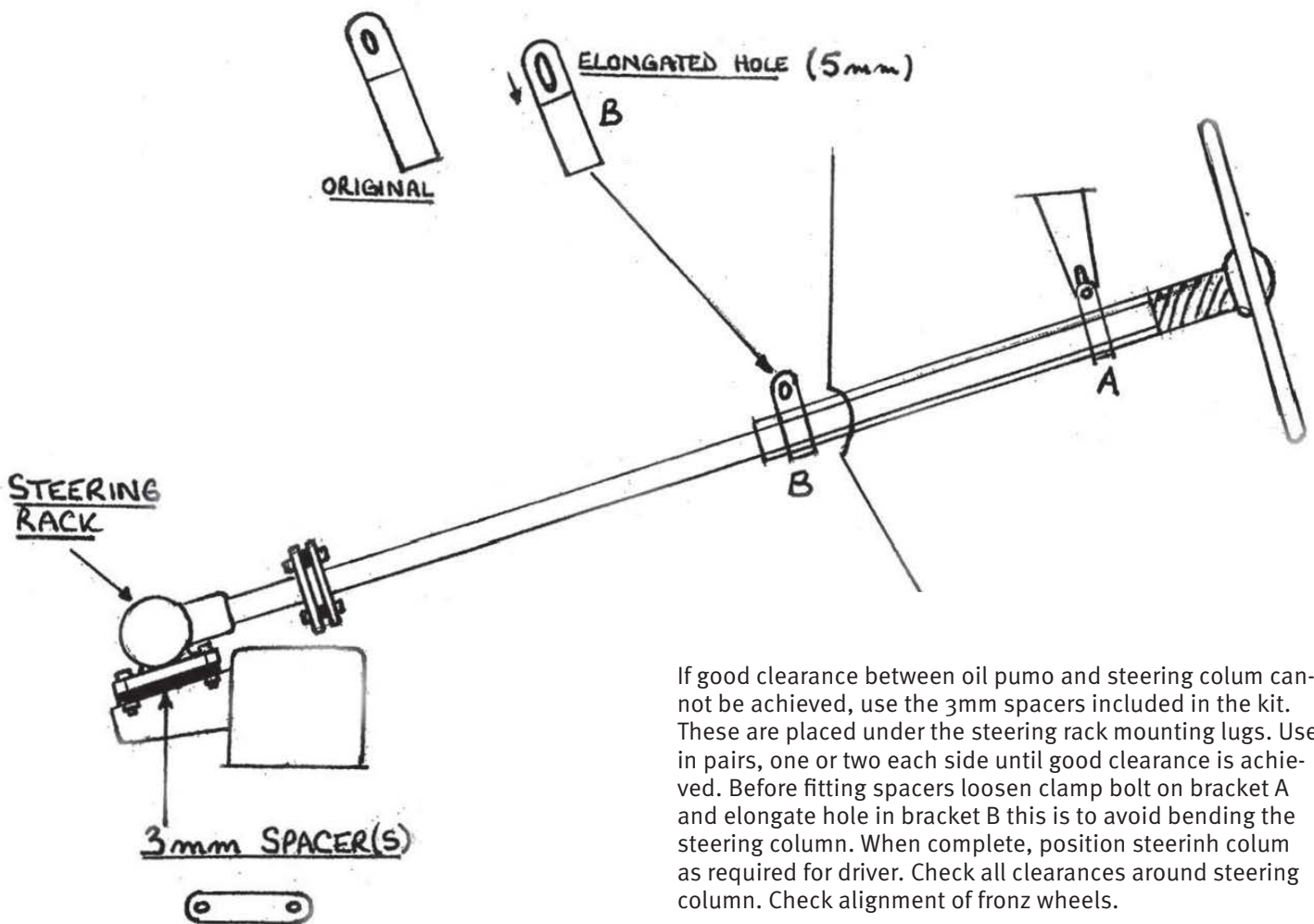

If good clearance between oil pump and steering column cannot be achieved, use the 3mm spacers included in the kit. These are placed under the steering rack mounting lugs. Use in pairs, one or two each side until good clearance is achieved. Before fitting spacers loosen clamp bolt on bracket A and elongate hole in bracket B this is to avoid bending the steering column. When complete, position steering column as required for driver. Check all clearances around steering column. Check alignment of front wheels.



**Limora Zentrallager**  
 Industriepark Nord 21  
 D - 53567 Buchholz  
 Tel: +49 (0) 26 83 - 97 99 0  
 E-Mail: Limora@Limora.com  
 Internet: www.Limora.com

**Filialen:**  
 • Aachen • Berlin • Bielefeld  
 • Düsseldorf • Hamburg  
 • Köln • Stuttgart

## TD/TF GEARBOX PREPARATION

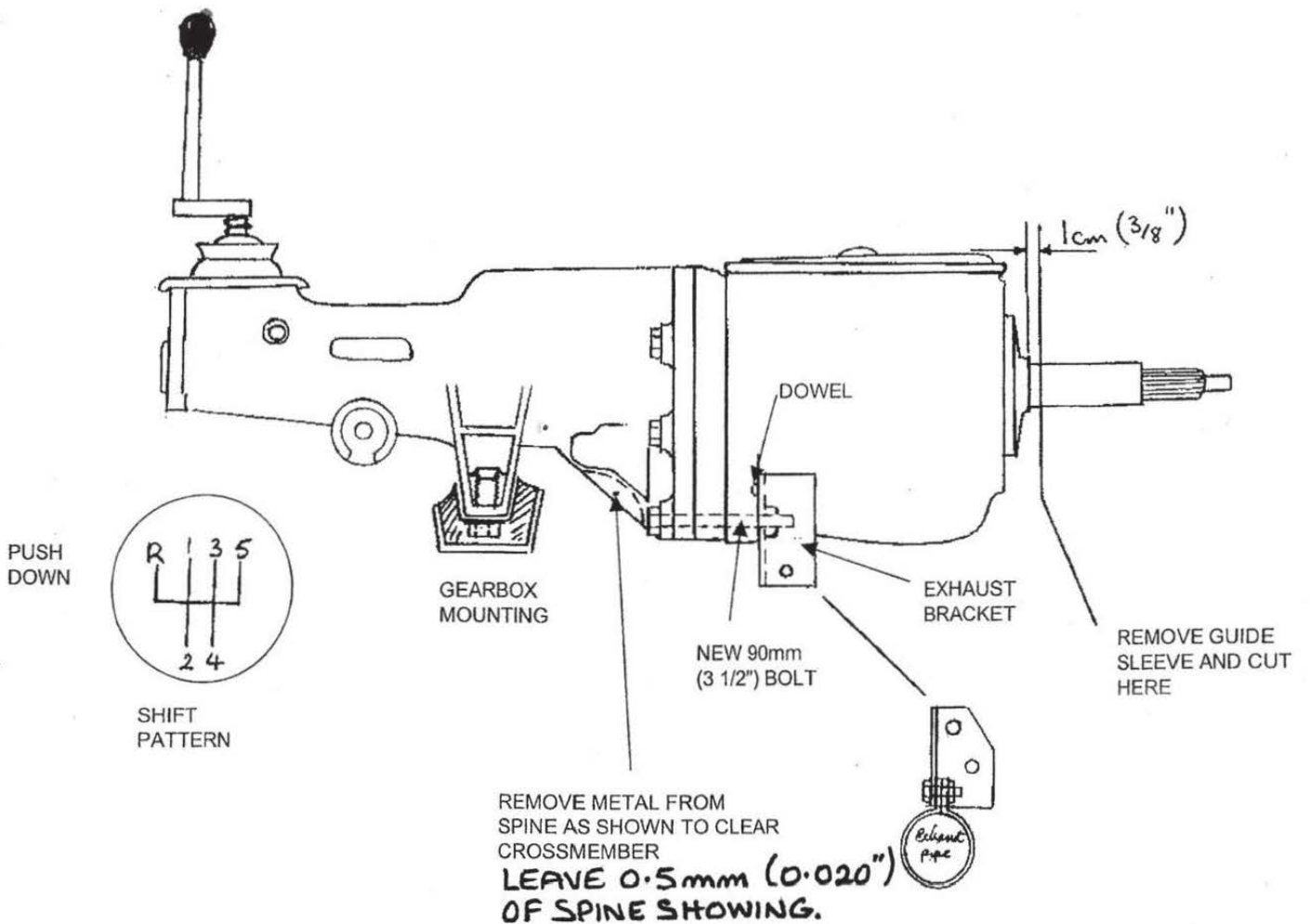

**Limora Zentrallager**  
 Industriepark Nord 21  
 D - 53567 Buchholz  
 Tel: +49 (0) 26 83 - 97 99 0  
 E-Mail: Limora@Limora.com  
 Internet: www.Limora.com

**Filialen:**  
 • Aachen • Berlin • Bielefeld  
 • Düsseldorf • Hamburg  
 • Köln • Stuttgart

## TD/TF ENGINE PREPARATION

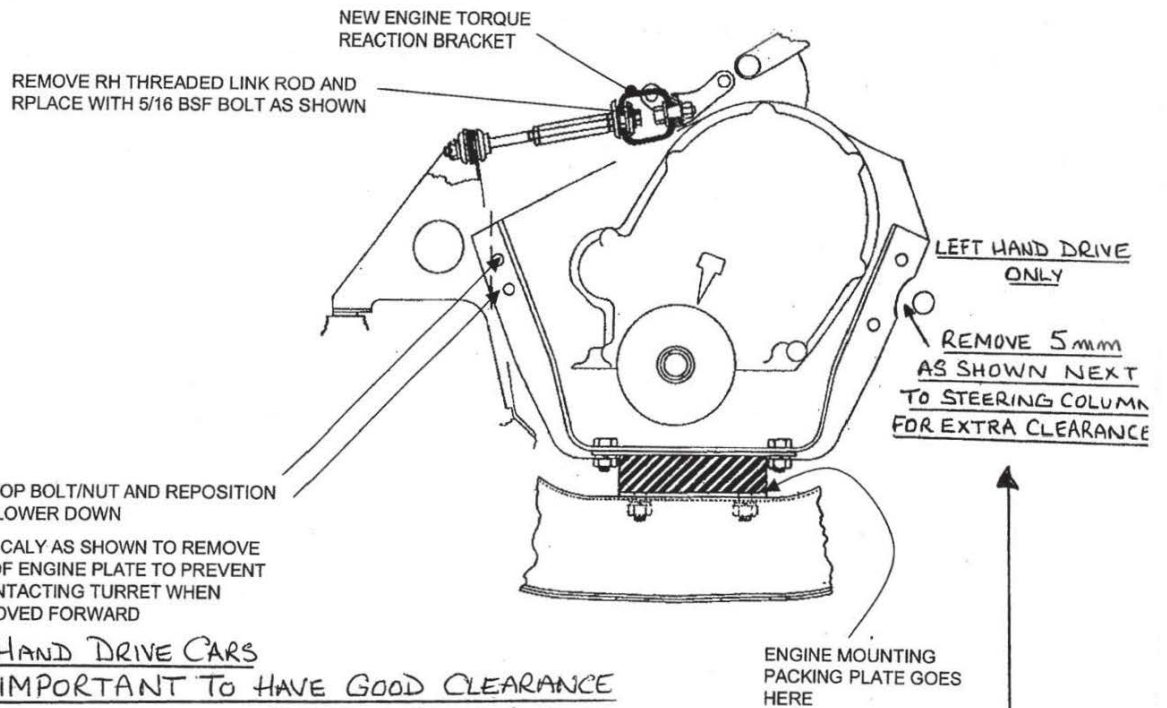

\*\*\*  
IMPORTANT

LEFT HAND DRIVE CARS  
IT IS IMPORTANT TO HAVE GOOD CLEARANCE  
BETWEEN ENGINE OIL PUMP AND STEERING  
COLUMN AND ENGINE FRONT PLATE / MOUNTING  
BRACKET AND STEERING COLUMN. ALLOW  
FOR ENGINE MOVEMENT

**Limora Zentrallager**  
 Industriepark Nord 21  
 D - 53567 Buchholz  
 Tel: +49 (0) 26 83 - 97 99 0  
 E-Mail: Limora@Limora.com  
 Internet: www.Limora.com

**Filialen:**  
 • Aachen • Berlin • Bielefeld  
 • Düsseldorf • Hamburg  
 • Köln • Stuttgart

## TD/TF NEW GEARBOX SUPPORT SYSTEM

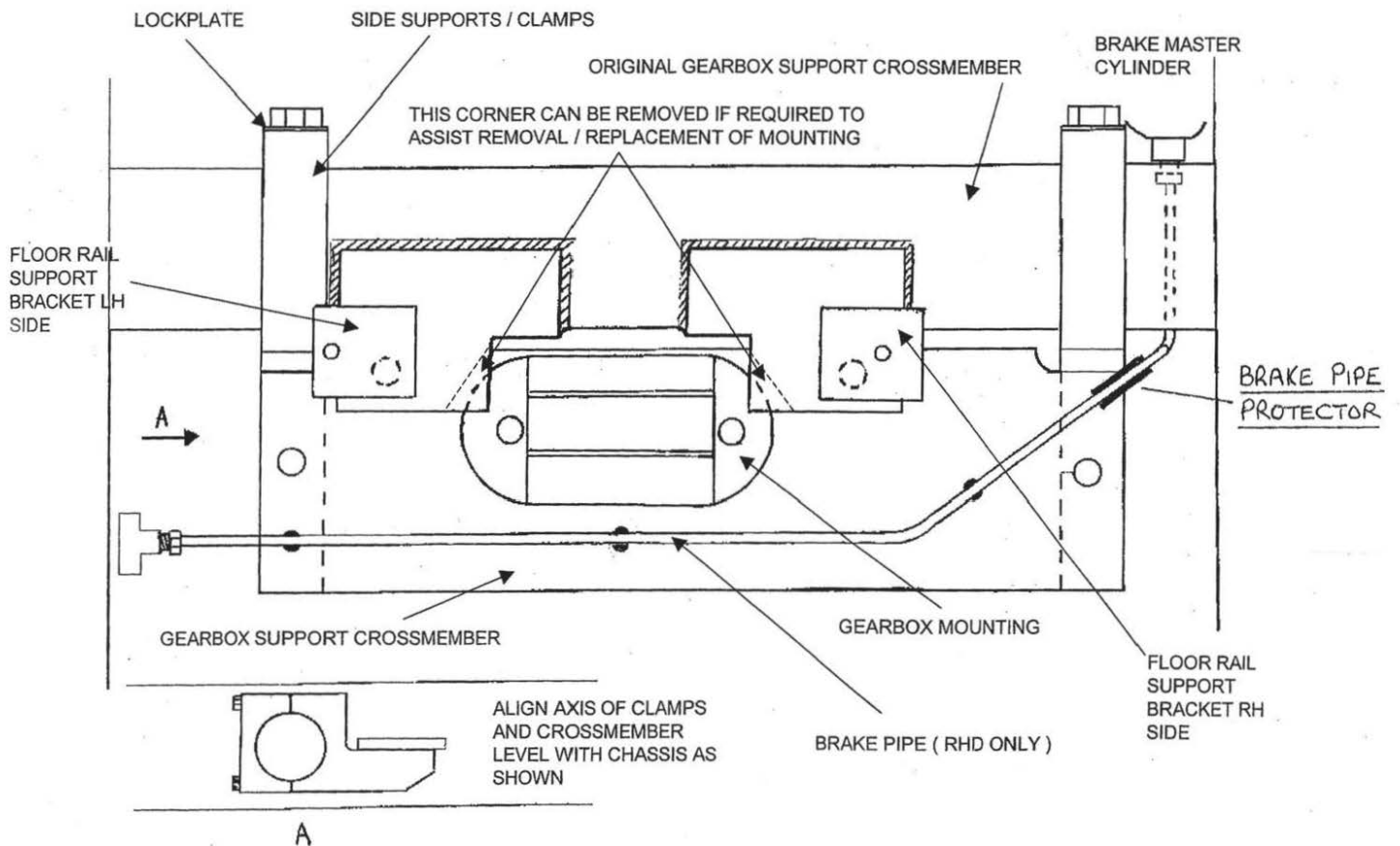



**Limora Zentrallager**  
 Industriepark Nord 21  
 D - 53567 Buchholz  
 Tel: +49 (0) 26 83 - 97 99 0  
 E-Mail: [Limora@Limora.com](mailto:Limora@Limora.com)  
 Internet: [www.Limora.com](http://www.Limora.com)

**Filialen:**  
 • Aachen • Berlin • Bielefeld  
 • Düsseldorf • Hamburg  
 • Köln • Stuttgart

## TD/TF CHASSIS PREPARATION 1

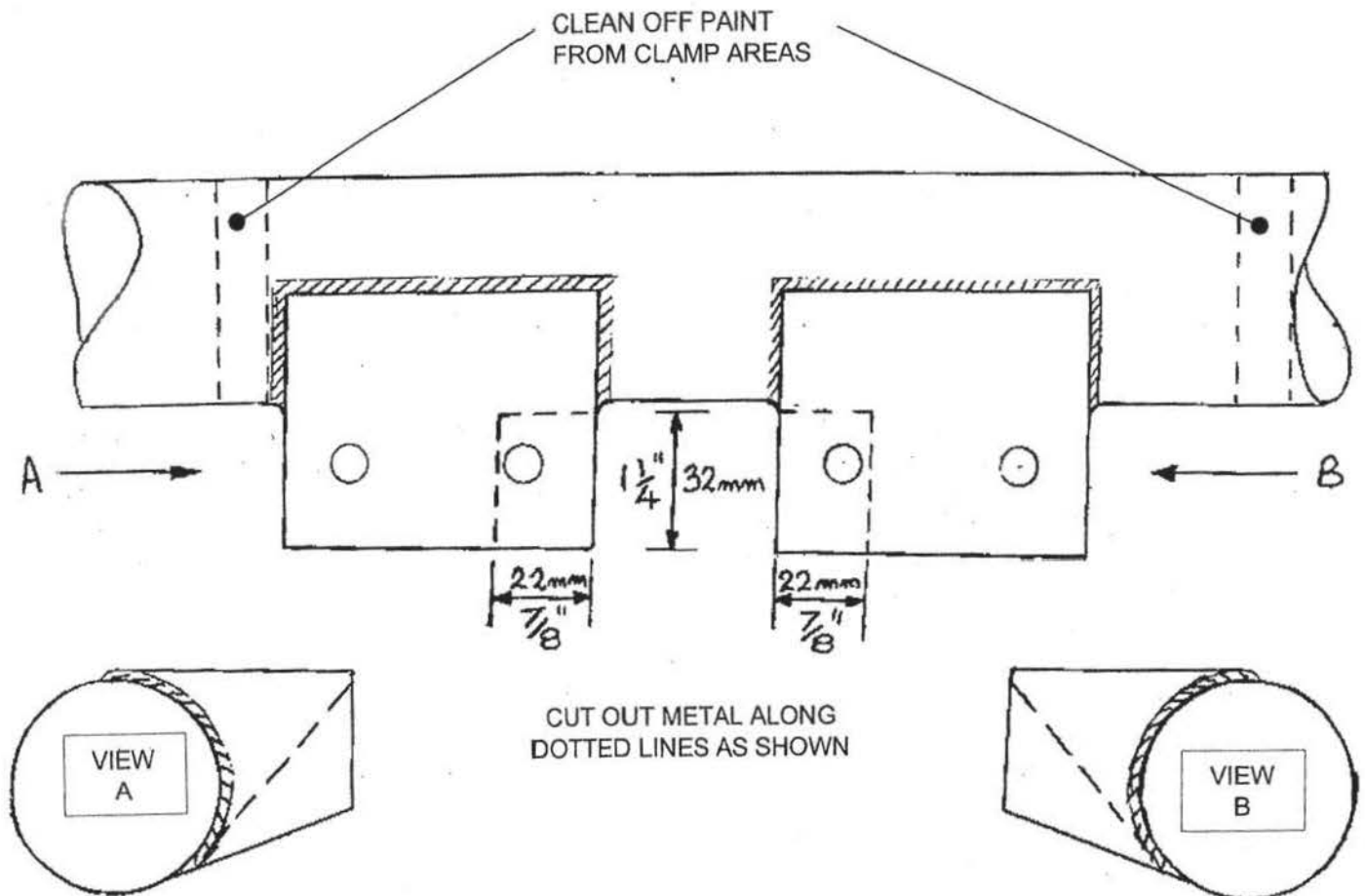

**Limora Zentrallager**  
 Industriepark Nord 21  
 D - 53567 Buchholz  
 Tel: +49 (0) 26 83 - 97 99 0  
 E-Mail: Limora@Limora.com  
 Internet: www.Limora.com

**Filialen:**  
 • Aachen • Berlin • Bielefeld  
 • Düsseldorf • Hamburg  
 • Köln • Stuttgart

## TD/TF CHASSIS PREPARATION 2



LH FLOOR RAIL SIDE VIEW REMOVE PIECE 45mm (1 3/4") X 8mm (5/16")



RH FLOOR RAIL SIDE VIEW  
 CUT OUT 12mm (1/2") X 38mm (1 1/2") FOR SPEEDO CABLE



RH FLOOR RAIL TOP VIEW  
 CUT OUT 38mm (1 1/2") X 8mm (5/16")  
 ONLY IF SPEEDO DRIVE STEP UP IS USED (CHRONOMETRIC SPEEDO)

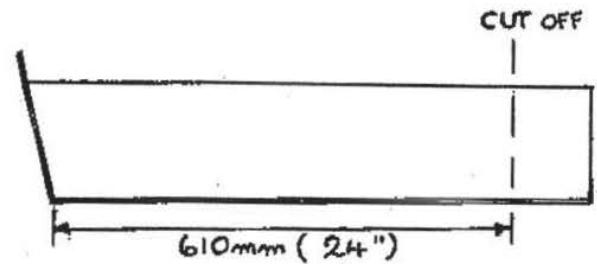

ORIGINAL PROPSHAFT TUNNEL (COVER)

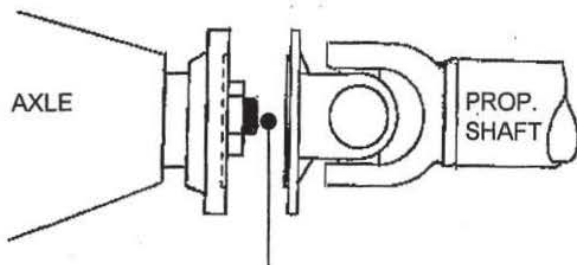

CHECK THESE THREADS  
 DO NOT BIND IN  
 PROPSHAFT FLANGE BASE

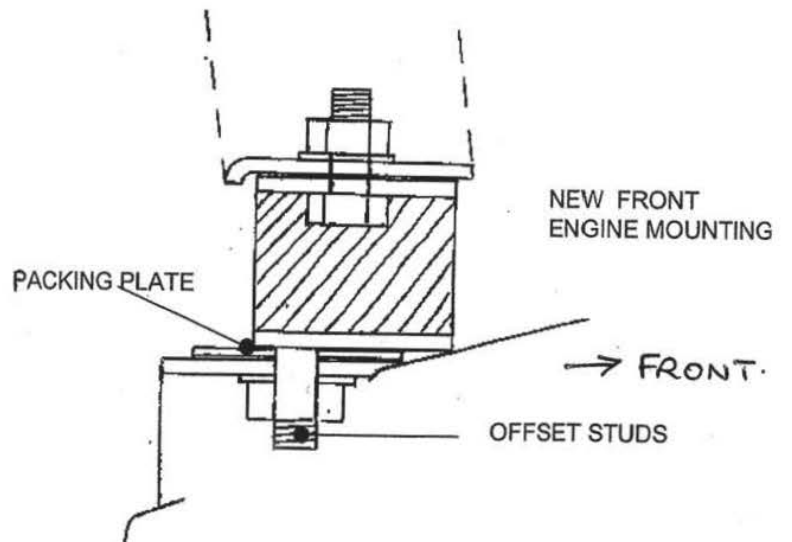

**Limora Zentrallager**  
 Industriepark Nord 21  
 D - 53567 Buchholz  
 Tel: +49 (0) 26 83 - 97 99 0  
 E-Mail: [Limora@Limora.com](mailto:Limora@Limora.com)  
 Internet: [www.Limora.com](http://www.Limora.com)

**Filialen:**  
 • Aachen • Berlin • Bielefeld  
 • Düsseldorf • Hamburg  
 • Köln • Stuttgart

## TJ TF Y GEARBOX SUPPORT

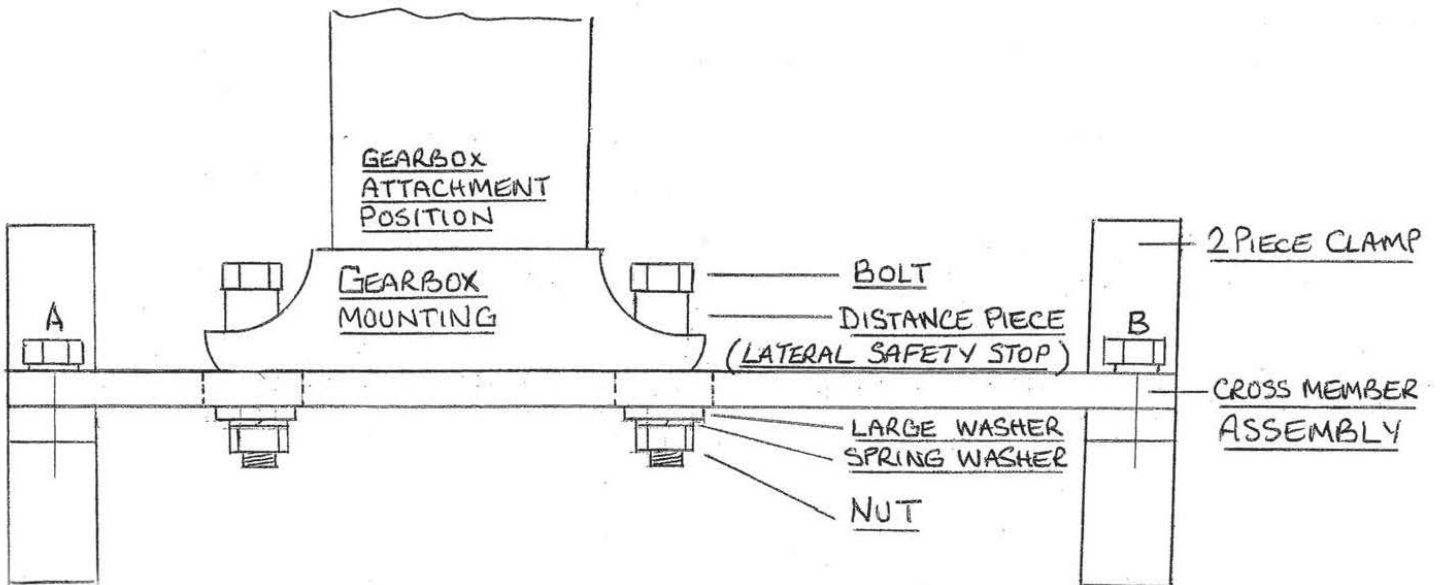

DIAGRAM SHOWING HOW GEARBOX MOUNTING  
IS ATTACHED TO CROSSMEMBER ASSEMBLY  
VIEW FROM REAR

CROSS MEMBER ASSEMBLY IS JIG ASSEMBLED  
DO NOT LOOSEN BOLTS A AND B

**Limora Zentrallager**  
 Industriepark Nord 21  
 D - 53567 Buchholz  
 Tel: +49 (0) 26 83 - 97 99 0  
 E-Mail: Limora@Limora.com  
 Internet: www.Limora.com

**Filialen:**  
 • Aachen • Berlin • Bielefeld  
 • Düsseldorf • Hamburg  
 • Köln • Stuttgart

TD/TF inspection plate

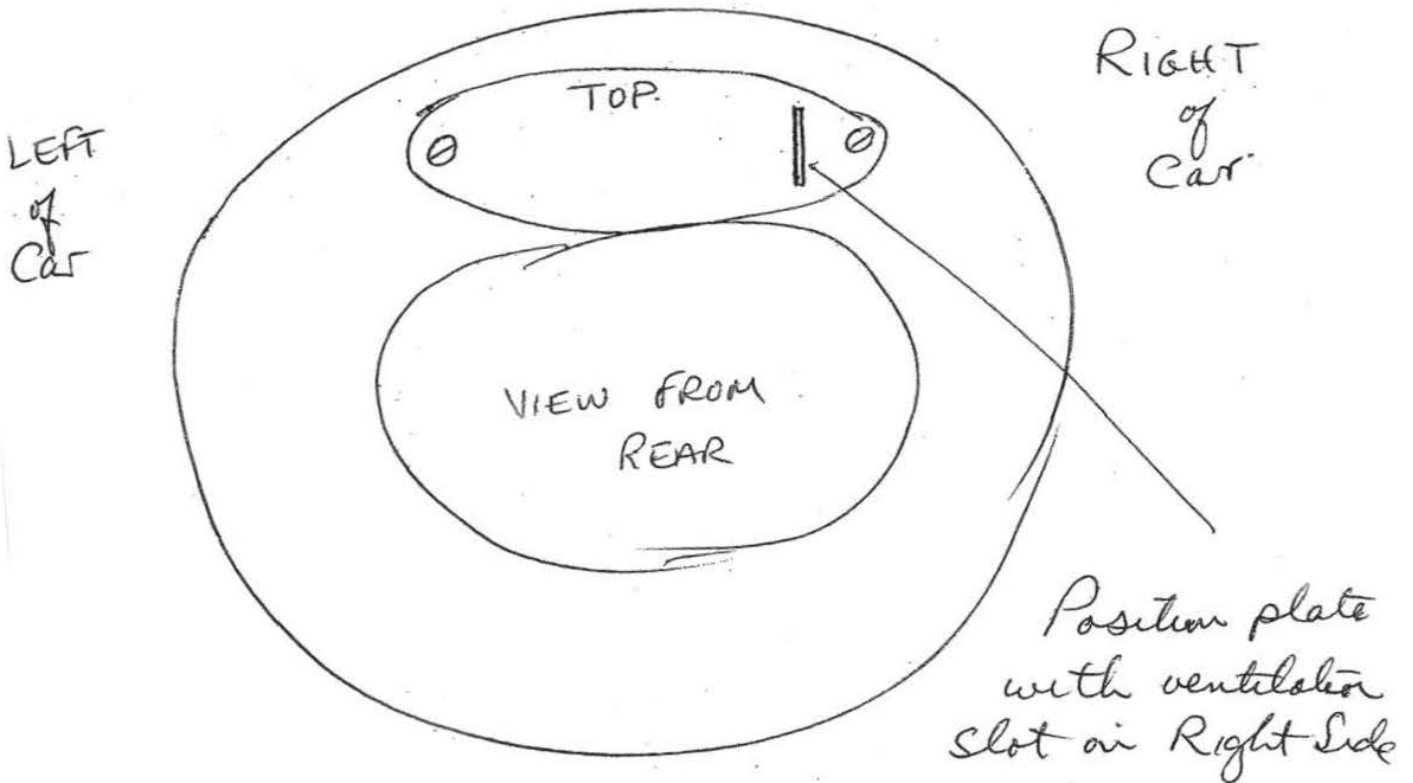

or oil leakage will arise from rear main bearing due to low air pressure (partial vacuum) in bell housing from centrifugal action of clutch pressure plate)

## OILS FOR TYPE 9 GEARBOXES

Specification 75w90 Gear Oil to API GL4

### Examples

Comma SX 75w90 API GL4

Redline MT 75w90, API GL4

DO NOT RUN ON AXLE STANDS. (STARVES REAR BEARING OF OIL)

DO NOT USE GL5 The extra antifriction additives\* will cause irreversible damage to the gearbox bearings. This will invalidate guarantee.

DO NOT USE ATF FLUID (Automatic transmission fluid)

DO NOT crank, start or run the engine without the correct grade of oil IN THE GEARBOX, otherwise damage to gearbox will occur.

\*current API GL5 formulations contain more antifriction additives than earlier API GL5 formulations.