

Limora Zentrallager

Industriepark Nord 21
D - 53567 Buchholz
Tel: +49 (0) 26 83 - 97 99 0
E-Mail: Limora@Limora.com
Internet: www.Limora.com

Filialen:

• Aachen • Berlin • Bielefeld
• Düsseldorf • Hamburg
• Köln • Stuttgart

Instructions

GENERAL NOTES ON INSTALLATION

1. It is preferable where possible to fit the throttle levers supplied, to the carburettor(s) before installation, and ensure that the throttles open and close freely prior to connecting the throttle linkage.
2. On twin carburettor installations the linkage body can be mounted on either carburettor to suit each application to allow the best accelerator cable route to be chosen. N.B. The linkage must be mounted so as to operate the chosen throttle lever between the two carburettors, (i.e. not on the outer end of one spindle).
3. Measure the accelerator cable travel on the existing installation, to assist in correctly adjusting the new linkage.
4. Lubricate the linkage with light oil during assembly.

THROTTLE LEVER FITMENT - Twin Carburettor Installation

N.B. It may be necessary in certain installations to remove the cast section of manifold between cylinders 2 & 3 to allow clearance for the new levers (1 & 2). a. Fit the new throttle levers (1 & 2) supplied, to the inside (facing) ends of the two carburettor throttle spindles. Lever (1) fits the throttle spindle on the fuel union side of the carburettor.

N.B. Fit shim washers (3) as required behind lever (1), do not fully tighten the spindle nut until the correct shimming is obtained. Ensure the original plain washers are fitted to the outer ends of the throttle spindles. Secure the throttle spindle nuts with the new lock tabs (4) provided.

THROTTLE LEVER FITMENT - Single Carburettor Installation

- a. Fit either of the two throttle levers (1 & 5) provided, to the carburettor, dependant on right or left hand actuation. Lever (1) fits the throttle spindle on the fuel union side of the carburettor. Ensure the original plain washer is fitted to the opposite end of the throttle shaft.

LINKAGE ASSEMBLY INSTALLATION

- a. Connect the link rod (6) to the throttle lever on the carburettor.
- b. Secure the base plate (7) supplied to the carburettor float chamber cover (LP1000/2000) using the three longer screws (8) and spring washers (9) supplied, or to the float chamber drain plate (LP3000/4000) using the original screws.

- c. Secure the linkage body (10) supplied to the base plate (7), and secure using the two M6 Nyloc nuts (11) with plain washers (12).
- d. Connect the remaining end of the link rod (6) to one of the five positions on the crank lever (13), dependant on the accelerator cable movement. The range covers 2640mm of cable travel.
- e. Fit the crank lever (13) to the linkage body (10) using the pivot pin (14) supplied, select the pivot pin position which offers the best link rod alignment.
- f. Secure the pivot pin (14) using the M5 plain washer (15) and M5 nyloc nut (16) provided. N.B. Do not overtighten the nyloc nut (16).
- g. Fit the over centre stop screw (17) and nut (18) provided.
- h. Fit the two throttle return springs (19) as shown, retain using the two remaining M5 plain washers (15) and split pins (20) provided.

ACCELERATOR CABLE CONNECTION (Single Cable)

- a. Screw the outer cable adjuster sleeve (21) into the linkage body as show
- b. Slide the existing accelerator cable through the adjuster sleeve (21) and secure the inner cable to the crank lever (13) using the adjustable ferrule (22).

ACCELERATOR CABLE CONNECTION (Twin Cable)

- a. Fit the connector block (23) provided to the accelerator pedal at the required position from the pedal pivot.
- b. With the accelerator pedal in the idle position mark out on the bulkhead the positions for the two diameter 6.5 holes 20mm apart.
- c. Drill through the bulkhead and fit the cable sleeves (21), support washers (24) and secure using the spare M6 nuts (25) provided.
- d. Route the twin cables (26) from the linkage through the bulkhead and secure to the pedal using the previously fitted connected block (23).

Limora Zentrallager

Industriepark Nord 21
D - 53567 Buchholz
Tel: +49 (0) 26 83 - 97 99 0
E-Mail: Limora@Limora.com
Internet: www.Limora.com

Filialen:

- Aachen • Berlin • Bielefeld
- Düsseldorf • Hamburg
- Köln • Stuttgart

- e. Retain the cables where necessary using the cable lies (27) supplied.

ACCELERATOR LINKAGE ADJUSTMENT

- a. Adjust the link rod (6) so that the crank lever actuating arm travels an equal distance above and below the horizontal axis, when traversing from idle to full throttle. N.B. The angle between the crank lever actuating arm and the link rod (6) in the full throttle position must not be less than 20 degrees.
- b. With the carburettor in the full throttle position adjust the limit stop screw (17) on the linkage body to meet the crank lever (13), fully tighten the lock nut (18).
- c. Adjust the outer cable so that the accelerator pedal reaches its limit stop as the carburettor reaches full throttle. **IMPORTANT:** Check the throttle operation before starting or road testing the vehicle.

NOTE: IT IS THE RESPONSIBILITY OF THE INSTALLER TO ENSURE THAT THIS LINKAGE IS SET AND FUNCTIONING CORRECTLY, AND THAT THE OVER CENTRE STOP WILL NOT ALLOW THE LINK ROD AND ACTUATING ARM TO BECOME IN-LINE.

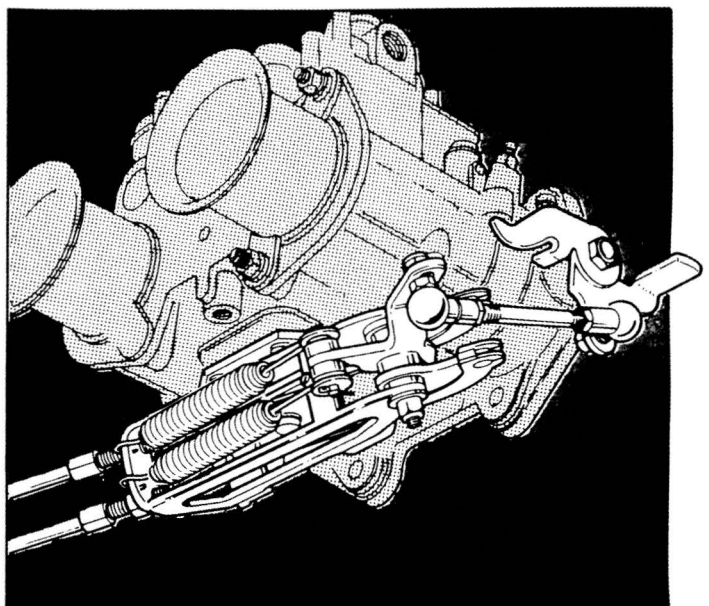
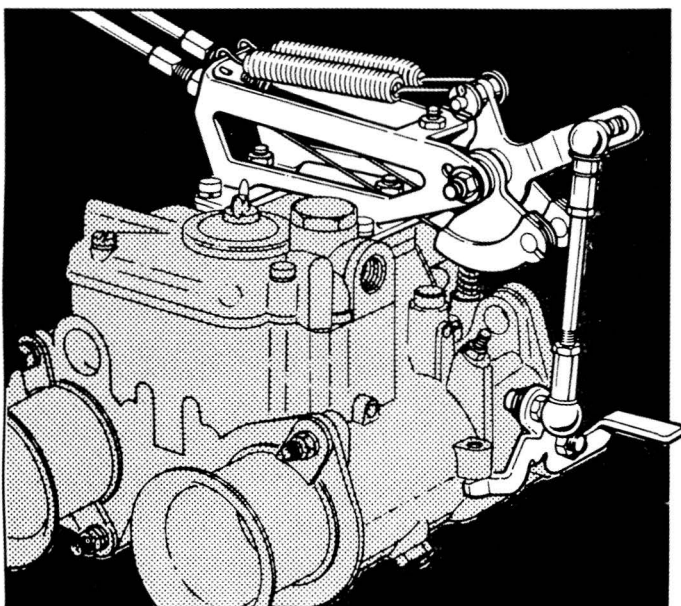

LINKAGES FOR DCOE CARBURETTORS

These have the following versatile features:

- Different versions for fitting above or below the carburettors.
- Different versions available for single or twin cable operation.
- All can be used on single or twin carburettor installations (for in-line engines)
- All can be fitted with the cable routed from either side.

the following safety features:

- Fitted with adjustable over-centre stop.
- Twin return springs.
- Twin sintered bronze self-lubricating quadrant bearings.
- High quality 8mm steel ball joints.

and the following other features:

- Inner cable connects to quadrant cam for smooth linear action.
- Light weight construction fabricated in zinc-plated steel, which matches existing steel components on the carburettor.
- Adjustment for throttle cable movement from 22mm to 40mm.
- Complete with all fitting accessories and a set of instructions.

DCOE Throttle Linkage System

Suitable for 38-55mm DCOE/SP Single & Twin Carburettors

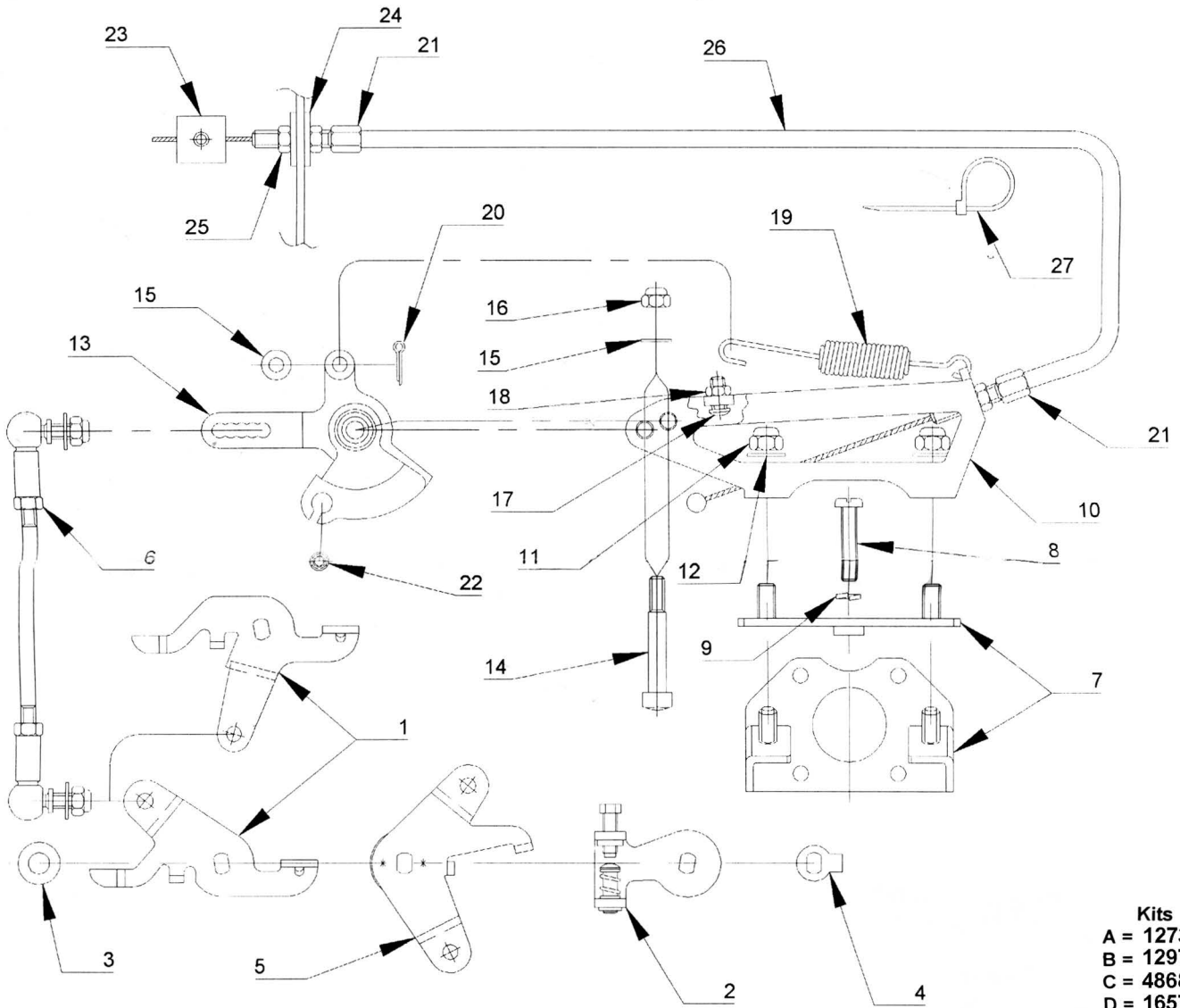

Kits
A = 12738
B = 12973
C = 486880
D = 16573

SPARE PARTS	PART NO.	DESCRIPTION	QUANTITY				DRG. NO.	PART NO.	DESCRIPTION	QUANTITY				DRG. NO.
			A	B	C	D				A	B	C	D	
	99901632	Throttle Lever	1	1	-	-	1	99901629	Pivot Pin	1	1	1	1	14
	99901641	Throttle Lever	-	-	1	1	1	99900290	M5 Plain Washer	5	5	5	5	15
	45048149	Throttle Lever	1	1	1	1	2	34725003	M5 Nyloc Nut	3	3	3	3	16
	55510128	Shim Washer	3	3	3	3	3	64595009	M5 Stop Screw	1	1	1	1	17
	55520004	Lock Tab	3	3	3	3	4	34715006	M5 Lock Nut	1	1	1	1	18
	99901704	Throttle Lever	1	1	1	1	5	99901155	Return Spring	2	2	2	2	19
	99901644	Link Rod - 100mm	1	1	1	1	6	99901631	Split Pin	2	2	2	2	20
	99901630	Base Plate	1	1	-	-	7	99901430	Cable Sleeve & Lock Nut	1	4	1	4	21
	99901640	Base Plate	-	-	1	1	7	99901558	Cable Ferrule	1	-	1	-	22
	99900762	M5 x 25 Screw	3	3	-	-	8	99901645	Connector Block	-	1	-	-	23
	99900024	M5 Spring Washer	3	3	-	-	9	99901591	M6 Support Washer	-	4	-	4	24
	99901626	Linkage body	1	1	1	1	10	34715010	M6 Nut (8 A/F)	1	6	1	6	25
	99900064	M6 Nyloc Nut	2	2	2	2	11	99901628	Accelerator Cable	-	2	-	2	26
	99900304	M6 Plain Washer	2	2	2	2	12	99900057	Cable Tie (150mm)	2	2	2	2	27
	99901627	Acc. Crank Lever	1	1	1	1	13							