



Supplemental Information & Instructions

for
ID 24108 Front Crankshaft Oil Seal, Lip Type
ID 24378 Gasket, Timing Chain Cover
ID 24380 Gasket, Oil Pan (2 Pieces)
MG TC, TD, TF

About this seal...

This modern lip-type seal replaces the original 2-piece "Karmal" rope-type seal, which is difficult to fit and prone to leak. The 24108 lip-type seal is retained in the original groove in the timing chain cover by a bead of silicone sealant. No machining is required.

The design of the T-Series block makes it necessary to drop the oil pan. It is always best to renew the oil pan gasket in addition to the timing cover gasket as part of the procedure. So many people have written for advice on how to cure persistent oil leaks from the timing cover area that we have expanded our instructions for fitting this seal to address these related problems. However, these instructions must be considered to be a supplement to, not a replacement for, the factory workshop manual.

Preparation

As with all instructions, read through all of the relevant sections in the factory workshop manual and this document before you pick up a tool.

Drain the oil, and remove the oil pan (Refer to the Workshop Manual section A1, A2)

Remove the timing chain cover (Refer to the Workshop Manual section A18)

Remove the old gaskets and clean the block, timing cover and oil pan gasket surfaces.

Carefully clean all traces of the old rope seal out of the timing cover groove and oil pan groove.

Check the fit of the new 24378 timing cover gasket. Paper gaskets shrink with age- they always have. If the holes in the gasket do not line up with the holes in the cover, soak the gasket in water for 5 to 10 minutes then dry the surface of the gasket with a paper towel, patting or blotting it dry rather than rubbing.

All parts should be clean, oil and grease free, and ready for assembly.

INSTRUCTIONS

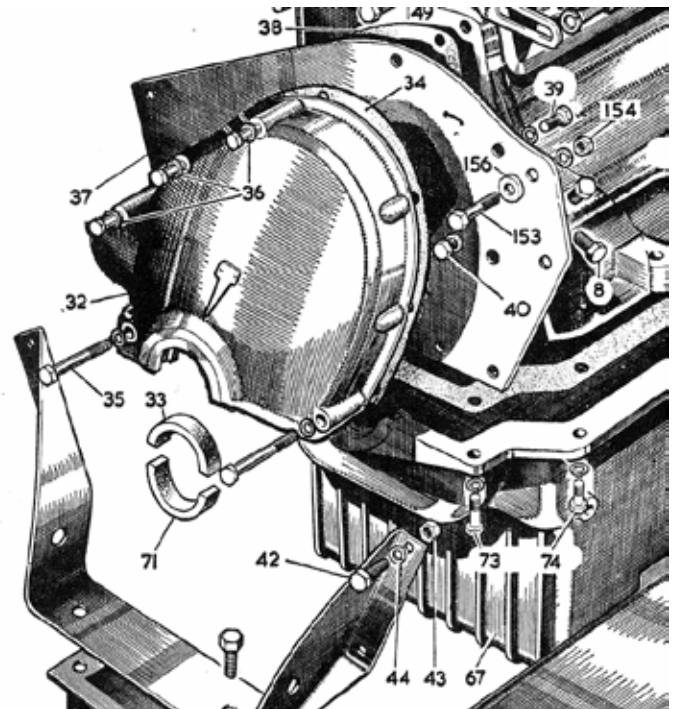

Illustration of the MG TF Engine from the Factory Parts Book.

Please Note:

The numbers in parenthesis in the instructions refer to the numbers in the diagram above.

Right and left are always relative to a person sitting in the cockpit facing forward.

- Look at the back of the timing cover and locate the open hole where one of the oil pan fixing bolts will go, Place a blob of silicone sealant over this open hole to prevent oil running down the threads and past the lock washer and bolt head.
- Secure the 24378 gasket (34) to the timing cover with a thin bead of silicone sealant.
- Squeeze a small bead of silicone sealant into the groove for the seal in the timing chain cover.
- Insert the seal in the timing cover groove as centrally as possible, making sure the open side of the seal faces the engine. The rubber seal is narrower than the groove; this is not a problem.

- Put a thin bead of silicone sealant on the other side of the timing cover gasket, then install the timing cover on the front of the engine but do not fully tighten the bolts. The timing cover is secured with seven 8 MM bolts of three different lengths. The two short bolts (39; 18mm long) enter from the rear. Of the five remaining long bolts, two are slightly longer and have thicker heads than the other three. These two slightly longer bolts (35; 51.5 mm long) go at the bottom of the cover, nearest the crankshaft. The remaining bolts (36; 44mm long) secure the right edge of the cover.
- After lubricating the seal surface of the crankshaft pulley with engine oil, carefully install the pulley through the seal.
- Visually check and move the oil seal so it is as close as possible to 90 degrees to the axis of the crank pulley.
- With the timing cover seal secured and centered, tighten the timing cover bolts.
- Install the crank pulley bolt and tighten it securely.
- Cut two small notches in the front ends of the 24380 oil pan gasket to fit around the seal in the timing cover.
- Secure the pan gasket to the pan with silicone sealant.
- Coat the cork seal on the rear main bearing cap with sealant.
- Put a bead of silicone on the exposed half of the timing cover seal.
- Coat the upper surface of the 24380 oil pan gasket with a thin film of silicone sealant.
- Put small dabs of silicone sealant in the recess in the front of the pan, around the two notches you just cut, and at the rear where the cork seal and pan gasket meet.
- Install the oil pan, fitting the two bolts at the back first, then the bolts where the gasket forks to join the bell housing, then work your way forward. Install all the bolts loosely at first. Once all the bolts are in, tighten them progressively rather than tightening each one “all in one go.”
- Refill the sump.
- If the crank was rotated while the pan was off, read the section on priming the oil pump in section A2 in the workshop manual.
- Let the sealant cure for 24 hours before starting the engine.
- Check the timing cover and oil pan carefully for leaks.